

### Over the Counter Roofing Approval Form

Applicant's Name: \_\_\_\_\_ Phone: \_\_\_\_\_  
 Project Address: \_\_\_\_\_

Please check the appropriate boxes. **Only check a box if it accurately and completely describes your proposed work, otherwise leave boxes blank.**

- A. Is the project structure 50 years old or older?**  Yes  No  
**B. Does the proposed work involve removal/replacement of original material?**  Yes  No  
**NOTE: If project is 50 years old or older, and the proposed work may involve removal/replacement of original materials, then the proposed work must be reviewed by Preservation staff and requires photos.**

**1. ROOFING TYPE**

- a. The original roofing material is:  dimensional composition shingle  wood shake or shingle  slate  
 clay or concrete tile  flat roof/membrane/hot mop  metal roof
- b.  The new roofing will match the original roofing, with no modifications (**3-tab roofing is not allowed as a full roof replacement, see 1c below.**)
- c.  Partial re-roof (50% or less) of 3-tab roofing will be placed to match existing 3-tab roof.
- d.  Existing 3-tab roofing will be replaced with:  dimensional composition shingle  wood shake or shingles  clay or concrete tile

**2. GUTTERS**

- a.  The original gutters are fascia gutters.  
 There is no change proposed to existing gutters.  
 New fascia gutters shall be repaired or replaced to match existing.
- b.  The original gutters are OG gutters.  
 There is no change proposed to existing gutters.  
 New OG gutters shall be repaired or replaced to match existing.
- c.  There are no existing gutters.  
 New fascia gutters shall be provided  New OG gutters shall be provided.
- d.  The existing gutters are Dutch gutters and:  Dutch gutters shall be repaired  Dutch gutters shall be covered and:  new OG gutters provided or  new fascia gutter shall be provided
- e.  Original downspouts will be repaired or replaced to match existing

**3. RAFTER TAILS**

- a.  There were no original exposed rafter tails.
- b.  There are original exposed rafter tails.  
 There is no change or cutting proposed to existing rafter tails  
 **Change is proposed to original exposed rafter tails (if this box is checked and the project is in a Design Review or Historic District, the project must be reviewed and work verified by Design Review or Preservation Staff prior to issuance of a building permit)**

**NOTE: Any work proposed that cannot be indicated by a checked box requires review by a Planner and/or Design Review/Preservation Staff prior to issuance of a building permit.**

**By signing below, the applicant certifies that this form accurately describes the proposed work.**

Applicant's Signature: \_\_\_\_\_ Date: \_\_\_\_\_

**FOR CITY STAFF USE ONLY**

Counter Staff: \_\_\_\_\_

- In a Design Review District and meets design criteria?  Yes  No (requires review & approval by DR staff prior to issuance of permit)  
 In a Historic District, or is it a Landmark structure?  No  Yes (requires review & approval by PB Staff prior to issuance of permit)  
 Not in a Design Review District; not in a Historic District, and not a Landmark structure

## Re-Roof Permit Design Review/ Preservation Guide

### Composition Roofing Materials

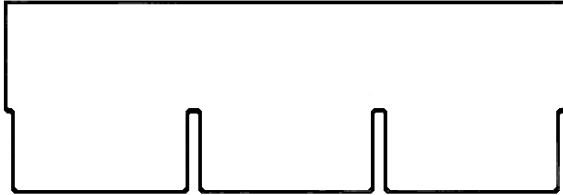

Three-tab NOT ALLOWED  
in Design Review Areas

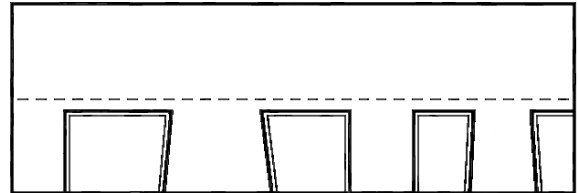

Laminated Dimensional  
minimum 30-year required

### Gutter Types

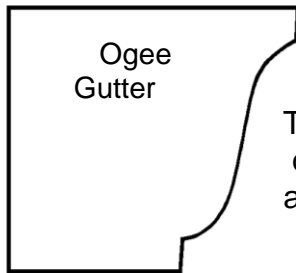

Ogee  
Gutter

Typical of  
older style  
architecture

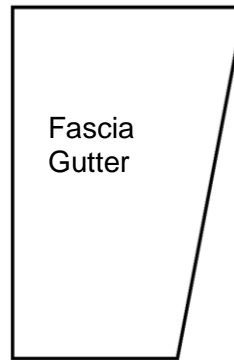

Fascia  
Gutter

Typical of  
newer 'modern'  
architecture

### Rafter Tails

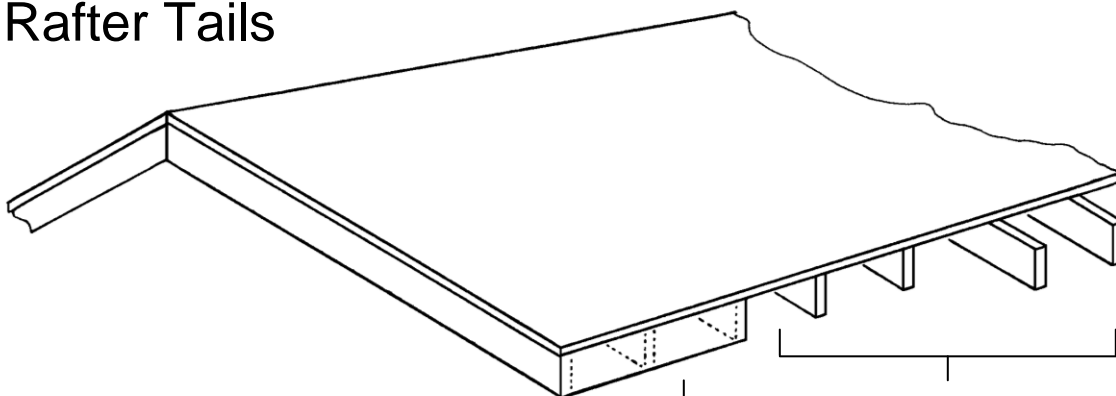

Fascia Board  
covering ends  
of Rafters

Exposed  
Rafter Tails